

SINTEF confirms that

### Sealmaster FB Eaves Vent – Flame Trapping Fire Damper

has been found to be fit for use in Norway and to meet the provisions regarding product documentation given in the regulation relating to the marketing of products for construction works (DOK) and regulations on technical requirements for building works (TEK), with the properties, fields of application and conditions for use as stated in this document



#### 1. Holder of the approval

Sealmaster  
 Dixon International Group Ltd  
 Brewery Road, Pampisford  
 Cambridge CB22 3HG  
 United Kingdom  
[www.sealmaster.co.uk](http://www.sealmaster.co.uk)

#### 2. Product description

The Sealmaster FB Eaves Vent is a unit with a reactive fire preventing system for the ventilation of roof constructions. The FB Eaves Vent incorporates technology to prevent flame transmission before a reactive intumescent material completely seals the unit in the event of a fire. The principle design and dimensions are shown in fig. 1.

The lower part consists of a 35 mm high grille with intumescent material based on graphite, protected on all four sides with a 0.7 mm thick perforated stainless-steel sheet. The lower grille protrudes 20 mm outside the frame on all four sides in order to facilitate fastening to the underside of the soffit. A 3 mm thick self-adhesive sealing strip is glued to the frame on all four sides, where the outer 1 mm consists of graphite.

The upper part consists of a 35 mm high and 10 mm wide wooden frame with slots for connecting one or two 0.46 mm thick stainless expanded steel rib mesh. This approval is applicable for vents with one steel mesh, described as "3-layer vent".

#### 3. Fields of application

The vent is installed horizontally at the eaves for the ventilation of roof structures in fire class 1, see fig. 2. The vent acts as a firestop for fires from the underside, by preventing flame penetration and blocking the ventilation when the temperature rises.

#### 4. Properties

##### Fire resistance

The vent, including the prescribed screw fixing, has 30 minutes fire resistance for separating and insulating function documented by testing partly according to EN 1363-1:1999, but with special adjustments for the product.

##### Effective ventilation area

The effective ventilation area is 32 % of the total area, i.e. 23 000 mm<sup>2</sup>.

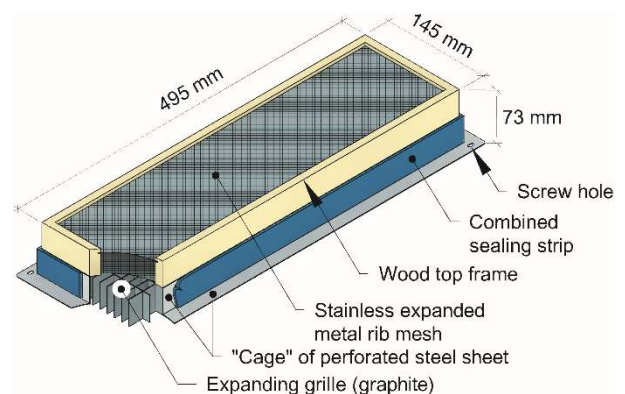

Fig. 1  
 Sealmaster FB Eaves Vent. Principle design and measures. Gross dimensions including flanges are 185 x 535 x 73 mm.

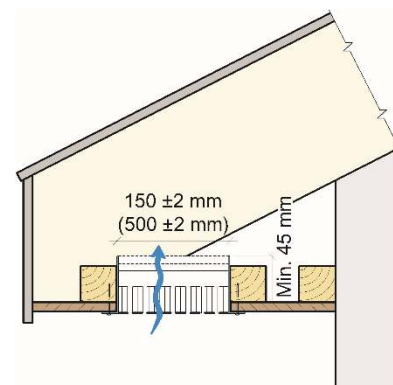

Fig. 2  
 Principle installation of Sealmaster FB Eaves vent. Also, the surrounding soffit design must have an equivalent fire resistance to obtain 30 min. fire resistance for the assembled eaves construction.

#### 5. Environmental aspects

##### Substances hazardous to health and environment

The Sealmaster FB Eaves Vent contains no hazardous substances with priority in quantities that pose any increased risk for human health and environment. Chemicals with priority include CMR, PBT or vPvB substances.

SINTEF is the Norwegian member of European Organisation for Technical Assessment, EOTA, and European Union of Agrément, UEAtc

#### *Waste treatment/recycling*

The Sealmaster FB Eaves Vent shall be sorted as residual waste. The product shall be delivered to an authorized waste treatment plant for energy and material recovery.

#### *Environmental declaration*

No environmental declaration (EPD) has been worked out for Sealmaster FB Eaves Vent.

### **6. Special conditions for use and installation**

#### *Design considerations*

The necessary ventilation of the roof construction must be determined in each individual case to decide the number and positions of vents.

To obtain a fire resistance of 30 min. for the eaves, the soffit construction where the vents are installed must also be designed for at least a 30 min. fire resistance.

#### *Installation*

The vents are installed in an airtight soffit board and a 500 mm ± 2 mm x 150 ± 2 mm opening, normally between roof rafters. The vent shall be fixed to battens on all four sides with minimum four 4.1 mm x 50 mm stainless steel screws. The battens shall be minimum 25 mm wide and with a minimum 45 mm height including the thickness of the soffit board.

#### *Surface treatment*

The vent must not be painted.

#### *Maintenance/cleaning*

The vent has no moving parts and does not require special maintenance to ensure that it will function in case of a fire. Visual inspection shall be done to ensure that the openings in the perforated steel sheets are not blocked by dust, insects etc.

It is recommended that an inspection is carried out every fifth year on the underside of the vent, and on the top side every tenth year, to decide whether cleaning is necessary. If cleaning is required it may be necessary to remove the vents for access.

### **7. Factory production control**

Sealmaster FB Eaves Vent is produced by Sealmaster, Pampisford, United Kingdom.

The holder of the approval is responsible for the factory production control to ensure that the product is produced in accordance with the preconditions applying to this approval.

The manufacturing of the product is subject to continuous surveillance of the factory production control in accordance with the contract regarding SINTEF Technical Approval.

The production is carried out according to the manufacturer's quality system which is certified according to ISO 9001: 2015 by SGS United Kingdom Ltd, certificate no. GB 10/80005

### **8. Basis for the approval**

The evaluation of Sealmaster FB Eaves Vent – Flame Trapping Fire Damper is based on reports owned by the holder of the approval.

### **9. Marking**

Sealmaster FB Eaves Vent shall be marked with manufacturer's product designation and a production number with date of production.

The approval mark for SINTEF Technical Approval No. 2405 may also be used.

### **10. Liability**

The holder/manufacturer has sole product responsibility according to existing law. Claims resulting from the use of the product cannot be brought against SINTEF beyond the provisions of Norwegian Standard NS 8402

for SINTEF



Hans Boye Skogstad  
Approval Manager